

Integrated Product Ontologies for Inter-Organizational Networks

Milan Zdravković¹ and Miroslav Trajanović¹

¹ Faculty of Mechanical Engineering, University of Niš,
Aleksandra Medvedeva 14, 18000 Niš, Serbia
{milan.zdravkovic, traja}@masfak.ni.ac.yu

Abstract. Purpose of this paper is to propose approach and technical infrastructure for improvement of inter-organizational networks' response in product information acquisition and management. Different approaches (industrial categorization schemes, functional decomposition and semantic web) for management of product information are analyzed in context of inter-organizational networks. Process for semantic alignment of product information is defined, resulting with generalized, two-dimensional model, consisting of design and functional perspective. The process is expected to decrease human intervention in product data exchange in networked environments, as well as to create added value, through possible recognition of design intent, automated referencing to related manufacturing competences and reuse potential. Current prototype of system comprises of product ontologies and interfaces for topological model submission and refinement by using lexical term and predicate matching and property transfer. Impact of using formalized functional perspective is only theoretically justified and it still needs to be verified.

Keywords: semantic web, product classification system, product ontology, inter-organizational network, supply chain management.

1. Introduction

In today's economy, a growing trend of customer orders diversification sets the high demands for flexibility of manufacturing enterprises and supply chains, while urging for continuous improvement of quality levels and reduction of delivery times. Where latter issues can be addressed by improving the supply chain integration, demands for flexibility often cannot be fully met by the manufacturing vendors alone, without structured access to wide range of product and service delivery competences of their partners. Hence, it is expected that supply chain management practices would have to evolve in order to enable efficient collaboration of loosely-coupled, different enterprises, assembled quickly to fulfill shorter term objectives. Some of the attempts made with goal to meet these requirements are related to

development and industrial implementation of new supply chain concepts: virtual enterprises and inter-organizational networks.

Virtual enterprise is temporary network of independent companies, who come together quickly to exploit fast-changing opportunities [1]. It is characterized by the temporal appearance of a supply chain, producing low volume and high variety of products, in diverse environment of competences, capabilities and resources, available to promise. Virtual enterprises are derived from inter-organizational network – kind of relatively long-term cooperation, in contrast to temporal forms of collaboration it sets up. Inter-organizational network is responsible for preparation, setup and lifecycle management of the virtual enterprise. Common sources of most of the problems related to management of inter-organizational networks are their complexity and temporality of virtual enterprises. These cannot be managed without specific use of advanced software systems. Some of the problems' consequences, related to system design are elaborated below.

Current supply chain strategies are relation-oriented, rather than transaction-focused, with growing tendency of reducing the number of suppliers because of the possible relation cost reductions. In contrast, approach of managing inter-organizational networks is characterized by less number of transactions with greater number of partners – network actors. Moreover, in practice, relations are dyadic – rarely expanded to include vendors' vendors or customers' customers. Lack of supply network transparency can significantly reduce the impact of integration benefits. It is obvious that approach of inter-organizational networks requires significant shift from what is considered as traditional supply chain management strategy towards loose-coupled, temporal relationships model. However, it also imposes a new approach in design of relevant software system for its implementation and support. While complexity of traditional supply chain interactions is managed by implementing standards, predefined frameworks and specialized IT platforms, this is not feasible when great number of partners is involved in selection and collaborative processes, because of the high costs involved. Investments in technical framework for enterprise integration, which could maximize the efficiency and productivity of the network, can not be justified in a short term. Hence, authors propose that software system for management of inter-organizational networks should be characterized by transparent, loose, dominantly asynchronous, externally coordinated integration, based on generic approach and semantic interoperability. This approach is currently being applied in development of Semantic Information Pool for Manufacturing Supply Networks (SIP4SUP).

Main focus of this paper is to explore and define SIP4SUP's module requirements for one of the crucial inter-organizational processes in inter-organizational networks – management of formalized product information throughout the supply chain, by all of its stakeholders, including customers, business brokers and partners. In its design, authors are using the experiences from implementing product data management in wide collaboration environments such as e-marketplaces. They propose the approach to overcome the problem of semantic ambiguities of products and

services classification schemes, imposed by combined usage of functional and design definitions of products.

Integrated product ontology approach is built upon the concepts of product topology modeling, functional product representation described in [2, 3], and work related to decomposition of enterprise capabilities into production competences [4]. This approach is aligned with requirements of inter-organizational networks, with objective to avoid complexity issues related to exchange of specialized product information between different stakeholders and enable correlation with production competences ontologies and traceability to design representation of the product. Specific attention is made at acquisition of design requirements, which is initiated by the customer and supported by automated reasoning in recognition of topological model. Structure of the product is semantically aligned with existing ontologies in order to simplify the customer relations and affected collaborations. Also, in order to maximize the added value of the acquisition process, a functional perspective to a product is introduced, aiming at provision of the background knowledge for identification of design intent.

Remainder of this paper is organized as follows. Next section aims at describing the experience relevant for design of the product management systems for inter-organizational networks, specifically, classification schemes and semantic web paradigm, and provision of the original critics view. Third section describes the basic concepts of technical implementation of the software system, currently being developed by authors – SIP4SUP. It includes also the core of this paper, formalization of the approach of using integrated product ontologies for acquisition and automatic or semi-automatic analysis of product requirements in inter-organizational networks. It proposes the infrastructure of integrated system for knowledge-based management of product information and describes the process of recognition of conceptual product models.

2. Theoretical background

Presented approach is partially based on similarity of unknown product information acquisition process for an inter-organizational network and product requirements definition in concurrent engineering. It is argued [5] that ambiguities, incompleteness, redundancy, lack of traceability and insufficient decomposition of requirements are typical issues of this process, mostly due to existence of multiple perspectives to a product.

As the baseline for development of an approach in management of product data information in inter-organizational networks, authors identify:

- Identification of different product views, their cross-references and authorities for their management;
- Using Semantic Web paradigm for technical implementation of distributed product data management;

- Using current e-marketplace collaboration concepts (classification schemes) for facilitation of procurement and purchasing processes;

Discussion of the topics above and relevant conclusions made by the authors is presented in this section.

For unambiguous representation of a product in collaborative environments, such as supply chains, it is important to identify and manage different product views of different stakeholders. Ownership of the product information is distributed – for example, while manufacturers own their technical specifications, distributors are responsible for managing price information, terms of delivery and payment, etc. Currently, this is being technically realized by using Semantic Web paradigm. Semantic Web technology stack is defined [7] as extension of the current web, bringing structure to the meaningful content of its pages, with goal to evolve it from the medium of documents for people, towards intelligent infrastructure, where data and information can be processed automatically, by agents or similar technology. Developing and managing effective product ontologies for internet-based product sharing [8] are not novel concepts. Many authors show that ontologies are primary tools for product development processes [2,9,10,11,12,13]. Today, it's easy to transform existing standard specifications, such as ISO 10303 (STEP) to OWL [14]. There are some results in using ontology-based approach for managing and sharing product-related information in extended supply chains [15]. Still, complexity and diversity of tools, necessary for enforcing completeness and integrity of product information make the fulfillment of semantic web vision very difficult in wide environments such as e-marketplace. However, this is not necessarily the case for inter-organizational networks. Authors' arguments for this statement and some design guidelines are presented in section 2.1.

Even from the single authority perspective, overall product representation comprises not only of its topological structure, but also of its dynamics, describing how it operates and interacts with the environment. Some existing efforts [6] show that efficiency of the design process can be improved at rate of 33% if some portions of particular domain knowledge and experience are embedded into a set of user-defined knowledge contents initially built in new CAx file. Dynamics of the product is usually described by its functional decomposition - encompassing generic functions of the product artifacts and achievement relations between them. Although functional decomposition could multiply the impact of product exchange process by capturing and sharing design intent, in traditional design process, this knowledge is usually left implicit, or inconsistent and scattered in documentation [3]. Hence, it is argued that functional domains of knowledge must be consistently defined and mapped to product design perspective [12], in order to obtain effective and useful representation.

Product classification schemes like UNSPSC or eClass, widely used in e-marketplaces, must be taken into account in structuring product information in inter-organizational networks. Enterprise usage of single global classification systems such as UNSPSC and eClass offer cost-effective procurement optimization and full exploitation of e-commerce capabilities. Scope and

volume of its impact is directly proportional to number of collaborations of a single enterprise, or supply chain roles. Potential impact is multiplied by the fact that virtual enterprises are characterized by production and delivery of small series of diversity of products, often with unknown design at the time of bid or even order. However, it is already found that both approaches lack both the required coverage of concepts and semantic precision and propose that reusing the classification schemes should be focused only to their attribute libraries [16]. Although both classifications can be formalized into ontologies [10,17], impact of a structured knowledge to enterprise performance depends largely on approach to formalization of existing classifications. Weaknesses of widely used industrial categorization schemes in knowledge-based environment are identified and elaborated in section 2.2.

2.1. Using Semantic Web Paradigm for Product Representation

While electronic marketplaces are too complex for common agreements on semantic product data exchange, collaboration networks of limited size, with loosely coupled competences and resources, such as inter-organizational networks, are expected to achieve feasible and beneficial application of product ontologies. This is particularly the case when some kind of external coordination (business brokers, business architects) of the network is involved. Some of the arguments for the statements above and some resulting design guidelines are listed below:

- Scope of the use of ontologies is limited, comparing to theoretically infinite domain in the e-marketplace. Therefore, they are much easier to manage. Ontologies can be exposed as stack of services to authorized network's partners – integral parts of inter-organizational processes;
- Extended product ontologies, implementing different product representations are open-access knowledge repositories, valuable for individual operations of network partners;
- Inter-organizational networks can serve a request for proposal for diversity of products and services, often with unknown design and even purpose at the time of a bid. Structured knowledge about diverse products, as well as technologies for their manufacturing, delivery, maintenance and retirement, accumulated in a process of a bid response and order fulfillment, can be reused in multiple occasions and, therefore, improve overall responsiveness and reduce risks of inaccurate cost-estimations;
- Once properly setup, product and service ontologies can be mapped to competence ontology, supporting infrastructure for automated response. Also, inverse references of competences to products and services are valuable tool for generation of networks' target market segments;
- Concentration and densification of the acquired knowledge on specific product families and complementary services could serve as the core of future knowledge-based extended enterprise;

Still, Semantic web approach could arise some problems in application for distributed management of product information. One of the obvious weakness of languages of Semantic Web (RDF or OWL), in general, is limited expressivity, featured by the lacks of cross-slot constraints and operations, property compositions and defaults. This can affect the reasoning of product ontologies. For example, without cross-slot constraints, it is not possible to define assembly (fitting) criteria and rules. Lack of expressivity affects also the incapability to provide a meaning to an empty slot – indicating missing, negative, or non-relevant value [18] of some product attribute. The most preferred approach to address this weakness is to use a rules language (such as RuleML) to complement existing ontologies for expressing the relations between concepts. In latter example, it can be used for providing the reference to a means for acquisition of empty data – a web service, stakeholder or automated reasoning.

Moreover, one particular issue of managing product information in collaborative environment is conflicts, caused by redundancy, generated by expansion of managed data domain, beyond the natural scope of each authority, due to Open World Assumption. For example, a distributor could publish the technical specifications of a pump product (otherwise owned by the manufacturer) in its ontology because the owner is continuously or temporarily disabled to provide this information (because of technical incapability or products are obsolete). Although information source in this case is non-authoritative, distributors could gain the authority over particular product information in time. Hence, trustworthiness of the information source must be evaluated in order to prevent data conflicts, for example, on basis of its data usage frequency.

2.2. Industrial Categorization Schemes and Product Data Management in Inter-organizational Networks

Existing classification schemes are showing lack of semantic precision due to combined usage of functional and design definitions of products and absence of appropriate cross-references. For example, one specific product, such as water pump can be defined by its functional representation - UNSPSC's code 4015151, as well as minimum of two design variations - 40151503 (Centrifugal pumps) and 40151546 (Axial pumps). Negative impact of the issue can be multiplied when values of specific product's functional features are taken into account – for example, high-pressure water pumps are designed as multi-stage pumps with centrifugal units. Functional representation is closely related to a purpose of the product, and therefore, desirable for a communication with customer and in design of complex assemblies. However, it is not suitable from the aspect of manufacturability, because it does not explicitly point to its internal design, from which manufacturing operations can be derived. Vice versa, although design representation of a product can be directly and explicitly referenced to

manufacturing operations required for its production, it does not contain any knowledge on a product capability.

Another issue of ontological representation of existing classifications is that they are valid only in pre-determined, well-defined context [10]. This means that both provider and requester of information must be aware of the format used in exchange. In addition to this, authors identify the request context to be very important in using the classifications. For example, if customer requests for proposal of water pump, he is interested in its functional capabilities and quality features. Manufacturers need different perspective – design, and therefore, completely different set of information. Finally, industrial categorization schemes are descriptive languages. They were created with objective to aggregate entities for some purpose, rather than describing the nature of the entity [16], for example - its capability. Therefore, they are very hard to maintain and evolve, especially when different contexts of product or service description are involved. In today's economy, concepts related to products and services are dynamic and volatile. Terminology changes, retirement of existing concepts and introduction of new ones are frequent, particularly at the highest levels of precision in industrial categorization – lowest nodes of taxonomies. Dynamics and volatility of concepts are much easier to manage when product or service is represented by set of meaningful statements or expressions, rather than narrative description.

Literal formalization of UNSPSC or eClass taxonomy for knowledge-based representation of products and services would have no significant impact for product management process efficiency. However, despite mentioned issues, using product classifications in product data management processes in inter-organizational networks will have significant positive effect at the efficiency of the collaboration, particularly in purchasing and procurement. Hence, authors propose the development of formalization approach which improves the semantic precision by establishing the relationships between functional and design-based concepts in independent data domains, and then referencing the product identification to its counterpart in a classification scheme.

3. Concept of the software system for management of product information in inter-organizational networks

Approach of the software system for management of inter-organizational networks is characterized by transparent, loose, dominantly asynchronous, externally coordinated integration, based on semantic interoperability. It is currently being applied in development of Semantic Information Pool for Manufacturing Supply Networks (SIP4SUP), a software platform with the associated configuration assets. Its main objectives are to:

- Expose individual partners' business services in collaboration space;
- Enable semi-automated or automated selection of competences relevant to meet customer product inquiries, based on transparent, realistic, actual

and measurable representation of individual capabilities, and cross-referenced, formalized representation of the product data;

- Coordinate collaborative performance of individual partners' business services within inter-organizational processes.

SIP4SUP exploits and builds on technologies for enterprise application integration – service oriented architecture (SOA) [19], enabled with semantic components, and supported by reference models and processes, represented by appropriate ontologies and templates. SIP4SUP is responsible for management of following types of information:

- Asset Data and Metadata. Information on partners' competences (location, ownership, products, resources, knowledge, historical performance etc.) availability, ontologies, registered services for pulling availability information and their service contracts;
- Competence availability data. Accurate Available-To-Promise stock for all products; Accurate schedule and scale for planned machining and human resources utilization;
- Networking affiliation data. Various aspects of networking and affiliation. Stock and resources availability data accessibility (synchronous or asynchronous), IPR (Intellectual Property Rights) issues, privacy issues, terms and conditions for affiliation, import and export permits, etc.

Integrated product ontologies are driving the SIP4SUP's module for knowledge-based management of product information, built upon the triangle or product topology, product function and UNSPSC ontology. Its infrastructure is presented in Figure 1, above.

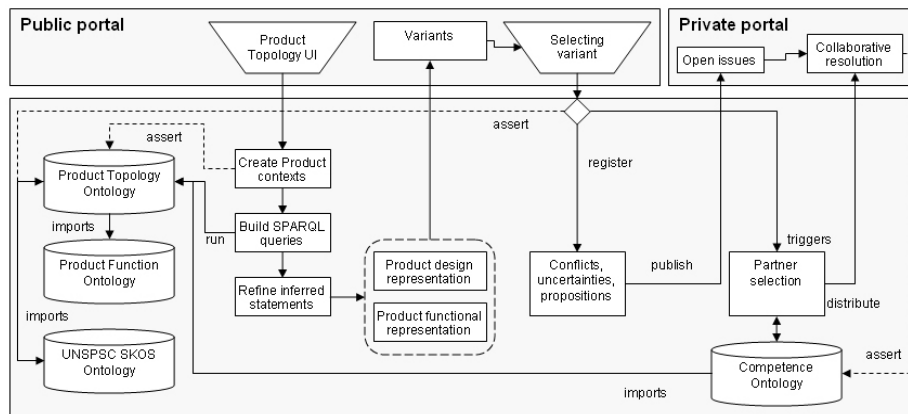

Fig. 1. Overall infrastructure of integrated system for knowledge-based management of product information

The primary focus of the inter-organizational network's collaboration is to enable response to diverse opportunities, manufacturing various classes of products in any volume required and capable to deliver. In manufacturing oriented supply chains, partners' competences are equally important for

response to a request for proposal (RFP), as current stock. One of the features of inter-organizational network is the capability to configure overall competences (design, manufacturing, logistics, etc.) of its partners towards fulfillment of specific goal – manufacturing and delivery, even with unknown design at the time of RFP receipt. Hence, performance of one virtual enterprise in response to RFP is influenced by the level of specialization of requested product specification and traceability of its elements to other production-related concepts. In this context, ultimate objective of SIP4SUP system is to enable automatic or semi-automatic establishment of references between product design requirements and production competences of inter-organizational network's partners.

As an example for the demonstration and theoretical validation of a presented formalization approach, a design of a low-pressure water pump – centrifugal pump (Figure 2) is used in this paper.

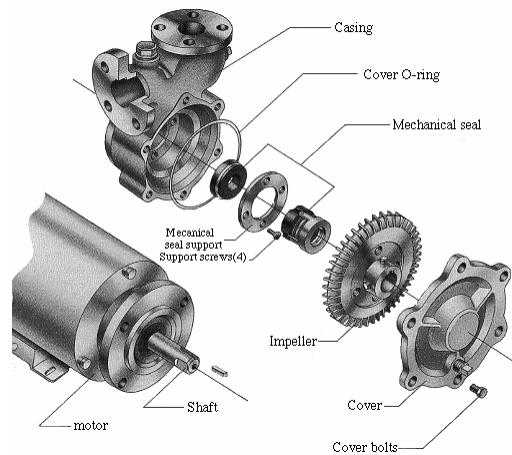

Fig. 2. Design of centrifugal pump

3.1. Product Design Perspective

Product design perspective aims at defining the topology of product artifacts, which are assigned with any of applicable stereotypes – product, subassembly, part (suppliable elements) or a feature. It is being acquired in collaborative process, during which initial product topology, acquired from the customer, is being specialized to geometric design model in last instance. Product definition is initiated by the customer or partner, then attempt to infer its semantics is made and finally, process is continued by resolving open issues. Last step is facilitated by external data services and partners of the inter-organizational network.

Using the product topology as a process input reflects the attempt to overcome the problem of parsing technical documentation, or annotated geometric models to appropriate formalized representation. Although extensive work in automatic recognition of technological features in solid models has been already done [20,21], still there is no fully functional solution on the market. At the moment, there is no agreement on universal neutral model (like STEP) which would represent the feature-based design - the most common method for creating models by using machining and design features.

Therefore, authors choose to enable customer to submit conceptual design model - abstract topology of the required product, which encompasses its design structure in enough detail to enable recognition by using the product ontology. This approach builds upon existing experiences in semantic web paradigm application, with goal to maximize the domain of inference with minimum data input and still, benefits from the application of product classification schemes in purchasing and procurement, vital processes of inter-organizational networks. Approach is characterized by integration of two ontologies: representation of the topology of mechanical products and parts, and formalization of UNSPSC ontology. Relevant fraction of developed product ontology is presented at figure 3.

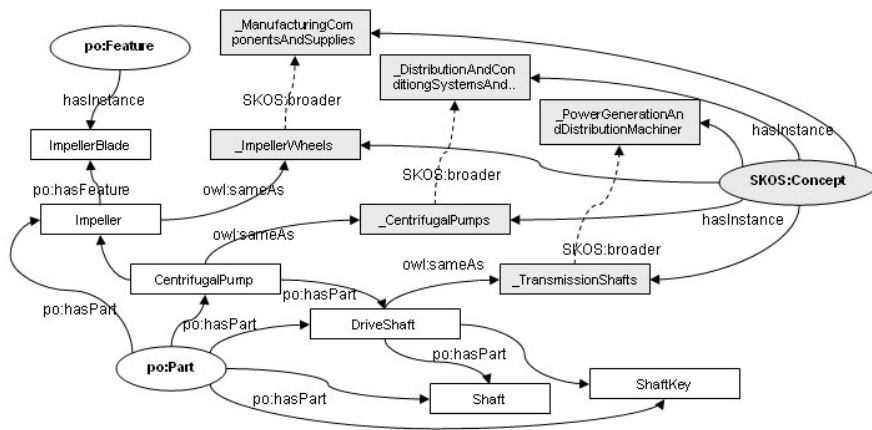

Fig. 3. Fraction of product ontology

Instead of literal formalization of UNSPSC, SKOS framework is being used. SKOS [22] is a family of formal languages, built upon RDF and RDFS for representation of thesauri, classification schemes, taxonomies or other type of structured controlled vocabulary.

Typical formalization approaches are using containment relationships (**rdfs:subClassOf**) between segments, families, classes and commodities in UNSPSC classification [23]. This could result with false inference when instances of Commodity classes are in ranges of properties which can be used for integration (due to enforcement of property transfer rule). Hence, SKOS concepts are being used for generalization of all UNSPSC terms,

interconnected by semantically “weaker” relationships `skos:broader` and `skos:narrower`. UNSPSC–SKOS ontology is automatically generated by transforming the W3C UNSPSC ontology with developed PHP script.

Product design topology is managed by using simple semantic framework, consisting of two classes: `po:Part` and `po:Feature`, one transitive and another non-transitive property: `po:hasPart` and `po:hasFeature`, consecutively (with appropriate inverse properties: `po:isPartOf` and `po:isFeatureOf`). All products and components are instances of `po:Part` class, with their counterparts in UNSPSC-SKOS ontology, identified by `owl:sameAs` relationships. Additionally, two inferred classes are defined as:

```
Assembly ≡ ((∃hasPart.Part)∩(∃isPartOf.Part))
Product ≡ ((∃hasUNSPSCCode.String)∩Part)
```

Classes above (as well as inferred properties `po:hasSubassembly` and `po:hasProduct`) are defined only by using sufficient conditions. It is obvious that this allows ambiguous inference in some cases. However, it is also desirable, because of uncertain product perspective of the system user.

By using the constructs above for assertion of topology relationships between the artifacts and classification containment relations, we can infer topology of the product. For example, figure 4 below shows asserted and inferred (italic font) statements of `DriveShaft` class.

```
hasPart Shaft
hasPart ShaftKey

isPartOf CentrifugalPump
isProductOf CentrifugalPump
isSubassemblyOf CentrifugalPump
isPartOf _CentrifugalPumps
hasPart _TaperKey
broader _KineticPowerTransmission
broader _BatteriesAndGeneratorsAndKineticPowerTransmission
broader
_PowerGenerationAndDistributionMachineryAndAccessories
hasUNSPSCCode "26111510"
```

Fig. 4. Asserted and inferred statements of `DriveShaft` class

Assertions from above are made in the process of ontology learning. At this point, SIP4SUP does not provide the facility for automatic product knowledge acquisition and referencing to UNSPSC classification nodes. This challenge will be addressed separately.

Main objective of design model’s conceptualization is to simplify the process of product design requirements definition by the customer. This process is very important in inter-organizational networks, where small volumes of diverse products are often manufactured and delivered with responsiveness as one of the crucial factors. Figure 5 shows the example of using product design concept user interface for submission of product design requirements.

Product concept

Part	element 0 title	Drive shaft	description or value		NEW CHILD	REMOVE
Part	element 1 title	Impeller	description or value		NEW CHILD	REMOVE
Feature	element 1.0 title	Blades	description or value		NEW CHILD	REMOVE
Product	element 2 title	Mechanical Seal	description or value		NEW CHILD	REMOVE
Subassembly	element 3 title	Pump body	description or value		NEW CHILD	REMOVE
Part	element 3.0 title	Cover	description or value		NEW CHILD	REMOVE
Part	element 3.1 title	Body	description or value		NEW CHILD	REMOVE

ADD NEW ELEMENT SUBMIT

Fig. 5. Interface for topological model submission

Upon submission of a topological model, appropriate XML file is generated and transformed into set of RDF statements. At this point, only relationships between objects (topology elements) are identified, where their definitions are not certain. Therefore, they are considered as blank nodes (bnode). For example, what is known about the model is that it consists of two parts, one of which has distinctive feature, one product and one subassembly, consisting of two parts.

Hence, unknown product is represented by graph notation as:

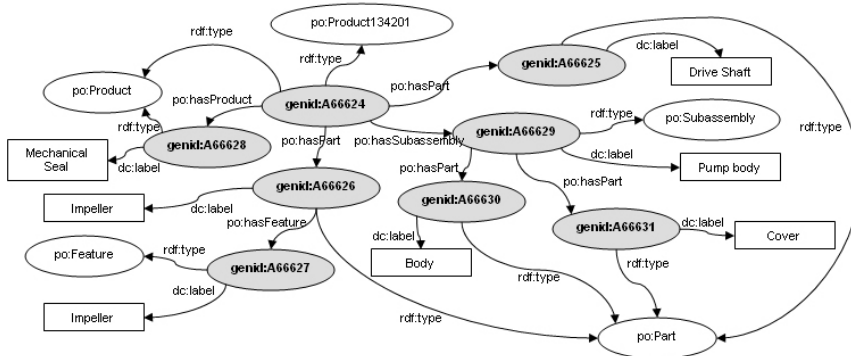

Fig. 6. RDF visualization of uncertain elements from the submitted topological model

Product information is further being processed in order to provide meaning to uncertain elements of the topology. A set of queries is generated, for each design element, with goal to identify known concepts from the product ontology, matching with uncertain elements. Lexical matches are initially inferred by using term and annotations from the ontology and then refined by querying topological relations, used in submitted model.

If multiple models are returned as proposed matches, user is enabled to confirm the choice, in which case he would be presented with selection of probable matches and a confirmation tool. It is likely that, even in case of confirmed model, there would be some non-matching terms (at any level of topology). If necessary, non-matching terms are conceptualized with manual

intervention by knowledge engineer or any other partner representative by using open issues web infrastructure.

Open issues are handled in special area of SIP4SUP portal where all gaps – uncertainties, missing values and non-matching terms are registered and distributed for manual resolution on basis of existing partner competence information. Where applicable, matching engine may also automatically propose new term location and its relations with known ontology elements. In this case, knowledge engineer is responsible for approval or modification of proposed transactions.

3.2. Formalization of Product Functional Perspective

For refinement and development of initial product concept, a functional perspective of a product is being used. Product function is defined as interpretation of behavior of the product in correlation with usage context and its subject or another product, affected by its performance [2].

Product function and its subject build the context for definition of objective of the product - defined as statement of a goal of its intended use. This concept is being generalized to all artifacts of one product - objectives and functions are identified on all levels of product concept representation – overall and subassemblies and parts.

Basic modeling constructs for representation of functional product perspective, according to the definition above are shown at Figure 7.

```

ContextualPart ≡ ((∃hasContext.Context) ∩ Part)
FunctionalPart ≡ (ContextualPart ∩
  ((∃hasEffect.ContextualPart) ∪
  (∃isAffectedBy.ContextualPart)))
  
```

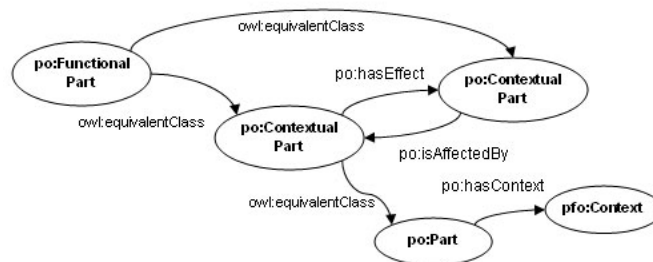

Fig. 7. OWL definition of FunctionalPart and ContextualPart artifacts

In this formalization approach, contexts are used to identify exact artifact function in certain circumstances. Namely, same individual can have different effects on different parts in multiple contexts, such as product, environmental and exploitation set of conditions.

For example, impeller in centrifugal pump provides an increase of the fluid pressure in the pump's casing, specifically, its discharge nozzle. However, in

water jets, impellers are used to power high speed boats. In order to differentiate artifacts' occurrences in multiple product contexts, we are going to use subclasses of a `pfo:ProductContext` concept, a subclass of `pfo:Context`, for example:

```
CentrifugalPumpContext ≡ ∃isPartOf.{CentrifugalPump}
```

Subclasses above are used as endpoints for inferences, related to individual products and represent formalization of suppliable products from the perspective of inter-organizational network. Specific product contexts are created and asserted into product ontology at the moment of product inquiries or in process of data acquisition, performed by knowledge engineers.

Moreover, different products can be identified as valuable, functional alternatives to designated ones, in different environmental conditions. For example, where complex facility is needed to make artificial snow at temperatures around 0°C, it is possible to make limited volumes at -10°C with simple car-wash compressors. In order to identify different outcomes of using different products in different environmental conditions, another specialization of `pfo:Context` is being used: `pfo:EnvironmentalContext`.

In contrast to its obvious meaning, `hasEffect` and its inverse counterpart `isAffectedBy`, are defined as non-transitive properties with goal to avoid inference of general statements, which have no impact on desired reasoning outcomes. However, in order to ensure the semantic precision, `hasEffect` is classified into taxonomy – providing its specialization paths (see Figure 8.).

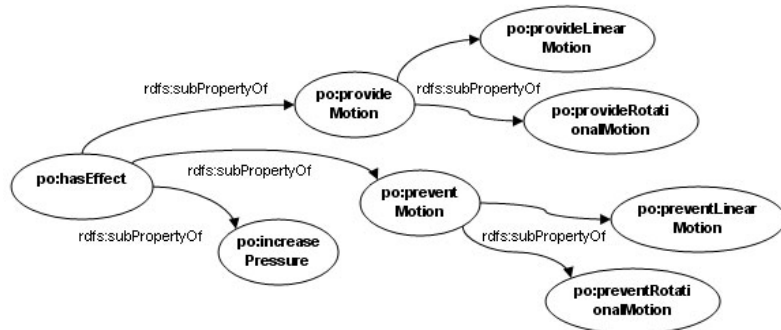

Fig. 8. Partial view of `hasEffect` concept specialization

Relevant properties are used for assertions of functional dependences of artifacts in `CentrifugalPump` product context. For example: drive shaft provides rotational motion to impeller; impeller increases a pressure in centrifugal pump casing by rotating in fluid; mechanical seal prevents linear (radial) motion of the drive shaft; etc.

Figure 9 below shows asserted and inferred (italic font) statements of `DriveShaft` class, after functional assertions are made to relevant artifacts in centrifugal pump context. Statements below are complemented to assertions and inferences made on the basis of topology of the product and classification containment relations, shown at Figure 4.

```
ProvideRotationalMotion Impeller

ProvideMotion Impeller
ProvideMotion _ImpellerWheels
ProvideRotationalMotion Impeller
ProvideRotationalMotion _ImpellerWheels
hasEffect CentrifugalPumpCasing
hasEffect PumpCasings
hasEffect Impeller
hasEffect ImpellerWheels
isAffectedBy MechanicalSeal
isAffectedBy _SealMechanical
hasUNSPSCCode "26111510"
```

Fig. 9. Asserted and inferred statements of functional representation of *DriveShaft*

Approach of using functional representation in process of product definition is related to its traceability to design representation in same or different contexts, defined by product functionality, environmental and exploitation conditions, and is justified by the following:

- Simple proposition of artifact variants is possible, by searching product ontology with function of any artifact, as input.
- Completely different artifacts can be identified as valuable, functional alternative to original ones, in different exploitation or environmental conditions.
- Causality relations between statements of goals of various artifacts are valuable source of knowledge - product design intent, reusable in multiple occasions.
- Functionality of the artifacts is usually related to its specific design characteristics, for example, shape, surface accuracy, special treatments in manufacturing process, etc.
- Customization of modular designs is much easier to manage.

4. Conclusion and Future Work

Work, presented in this paper is motivated by the obstacles in managing information in loose, temporal collaboration networks, particularly information of product requirements.

It is found that literal formalization of classification schemes is not suitable for application in this environment because of lack of semantic precision, ambiguity risks and usage of pre-determined context of communication. Yet, benefits of using classification schemes in procurement processes, which are vital for inter-organizational networks, should not be ignored. Therefore, concept of integrated ontologies is proposed, enclosing different, cross-referenced perspectives on product design and functionality, including SKOS-based formalization of UNSPSC scheme. Implementation of the concept in

SIP4SUP is currently ongoing, where formalization approach and interface for topological model submission and its refinement are presented in this paper.

Understanding the information in inter-organizational networks is very important issue, because of diversity of the products involved and lack of capability of one network to provide and use specialized knowledge in each and every occasion of business opportunity. Ontologies are identified as valuable tools for improvement of understanding, mainly because of semantic precision of the exchanged information, they provide. They enable a structured dialogue between all stakeholders of the manufacturing inter-organizational network, facilitated by automatic reasoning, and therefore, improve the efficiency of collaborative processes. Current state-of-the-art in using semantic web concepts for Enterprise Application Integration [24] provides additional arguments for focusing on using ontologies as primary means for facilitating business collaboration.

Top-down process of definition of product requirements and its cross-references with different product perspectives creates the opportunities for risk mitigation by providing early overview of the general context in which the product would be manufactured and supplied. It can be enabler for proposing variant solutions, as well as cross-sale and up-sale opportunities.

Finally, generic process is qualified for usage in other, different disciplines and occasions, for example – managing software requirements in outsourcing development.

Focus of the future work is on facilitating automatic knowledge acquisition and implementing functional perspective for further refinement of the product model and gaining additional benefits. Correlations between functional and design representation of the model constitute design intent and therefore, enable its capturing within unified representation. Traceability of overall product objective, to product's functional features, through its functional and geometric topology, is valuable means for resolving issues in collaboration of product designers and production engineers. Also, the design representation of the product can be defined as a realization of its functional representation.

It is obvious that one product or part function could be realized with different designs. By using the described system for product design definition, it is possible to develop the library of solutions for achievement of specific objectives, not only constituent parts of the products. Such library is valuable tool for product designers when it is necessary to respond quickly to market opportunity where requirements of the product are not known in advance, but its functionality is. Also, even when requested product's design structure is defined by the customer, library of solutions can be used for proposing variants, used for achievement of requested objectives, which can be manufactured and delivered by the virtual enterprise, with conditions favorable for the customer.

5. References

1. Browne, J., Zhang, J. (1999) "Extended and virtual enterprises – similarities and differences" *International Journal of Agile Management Systems*, Vol. 1, No.1, pp. 30-36
2. Kitamura, Y., Mizoguchi, R. (1999) "Towards Redesign based on Ontologies of Functional Concepts and Redesign Strategies", *Proceedings of 2nd International Workshop on Strategic Knowledge and Concept Formation*
3. Kitamura, Y., Mizoguchi, R. (2003) "Ontology-based description of functional design knowledge and its use in a functional way server", *Expert Systems with Applications*. Vol. 24, No. 2, pp. 153–166
4. Zdravković, M., Trajanović, M., (2007), "SOA-based framework for supply chain selection in network of production competences", *Proceedings of IWC-TQM, Belgrade*
5. Kott, A., Peasant, J.L. (1995) "Representation and management of requirements: The RAPID-WS project", *Concurrent Engineering: Research and Applications*. Vol. 3, No. 2, pp. 93-106.
6. Stojkovic, M., Manic, M., Trajanovic, M., "Knowledge-Embedded Template Concept", *CIRP - Journal of Manufacturing Systems*, Vol. 34 (2005), No 1
7. Lee, T.B., Hendler, J., Lassila, O. (2001), "The Semantic Web", *Scientific American*, May 2001
8. Zhang, S., Shen, W., Ghenniwa, H. (2004), "A review of internet-based product information sharing and visualization", *Computers in Industry*, Vol.54, No.1, pp.1-15
9. Kitamura, Y., Mizoguchi, R. (2004) "Ontology-based systematization of functional knowledge", *Journal of Engineering Design*, Vol. 15, No. 4, pp. 327-351
10. Hepp, M. (2006) "Products and Services Ontologies: A Methodology for Deriving OWL Ontologies from Industrial Categorization Standards" *International Journal on Semantic Web & Information Systems*, Vol. 2, No. 1, pp. 72-99
11. Lee, J., Suh, H., H., S.H. (2005) "Ontology-based Knowledge Framework for Product Development", *Computer-Aided Design and Applications*, Vol. 2, No. 5, pp. 635-643
12. Dori, D., Shpitalni, M. (2005) "Mapping Knowledge about Product Lifecycle Engineering for Ontology Construction via Object-Process Methodology", *Annals of the CIRP*, Vol. 54, No.1, pp. 117-120
13. Kitamura, Y., Kashiwase, M., Fuse, M., Mizoguchi, R. (2004) "Deployment of an Ontological Framework of Functional Design Knowledge", *Advanced Engineering Informatics*, Vol. 18, No.2, pp. 115-127
14. Klein, L. (2008), "SemanticSTEP – Linking ISO 10303 with the Semantic Web", 10th NASA-ESA Workshop on Product Data Exchange, Noordwijk, The Netherlands
15. Gimenez, D.M., Vegetti, M., Leone, H.P., Henning, G.P. (2004), "Product ONTOlogy: Defining product-related concepts for logistics planning activities", *Computers in Industry*, Vol.59, No.2-3, pp.231-241
16. Hepp, M. (2006) "The True Complexity of Product Representation in the Semantic Web", *Proceedings of 14th European Conference on Information System (ECIS 2006)*
17. Klein, M. (2002) "DAML+OIL and RDF Schema representation of UNSPSC", Available from: <http://www.cs.vu.nl/~mcaklein/unspsc/>, [Last Accessed November, 27th, 2007]

Milan Zdravković and Miroslav Trajanović

18. Di Noia, T., E. Di Sciascio, F.M. Donini and M.Mongiello (2003) "A System for Principled Matchmaking in an Electronic Marketplace", Proceedings of 12th International World Wide Web Conference
19. MacKenzie, C.M., Laskey, K., McCabe, F., Brown, P.F., Metz, R. (2006) "Reference Model for Service Oriented Architecture 1.0", Available from: <http://www.oasis-open.org/committees/download.php/19679/soa-rm-cs.pdf>, [Last Accessed November, 27th, 2007]
20. Vandenbrande, J.H., Requicha, A.A.G. (1993), "Spatial reasoning for the automatic recognition of machinable features in solid models", IEEE Pattern Analysis and Machine Intelligence, Vol. 15, No. 12, pp. 1269-1285
21. Di Stefano, P., Bianconi, F., Di Angelo, L. (2004) "An approach for feature semantics recognition in geometric models", Computer-Aided Design, Vol. 36, No. 10, pp. 993-1009
22. Van Assem, M., Malaise, V., Miles, A., Schreiber, G. (2006), "A Method to Convert Thesauri to SKOS", Proceedings of 3rd European Semantic Web Conference, ESWC 2006, Budva
23. W3C UNSPSC Ontology.
24. Anicic, N., Ivezic, N. (2005), "Semantic Web Technologies for Enterprise Application Integration", Computer Science and Information Systems, Vol. 2, No. 1

Milan Zdravković is research and teaching assistant at Faculty of Mechanical Engineering, University of Niš. His work is focused but not constrained to using semantic web tools and languages and SOA for facilitating inter-organizational collaborative forms, such as manufacturing supply chains.

Miroslav Trajanović is full professor at Faculty of Mechanical Engineering, University of Niš. He managed more than 30 national and international projects, including FP6 and FP7, dealing with wide range of ICT-related problems, delivering theoretical and practical state-of-the-art solutions.

Received: July 21, 2008; Accepted: October 19, 2009.